



GENUINE NISSAN ACCESSORIES

Nissan 4G WiFi & Apps

Marketing Support Bulletin

Reference: NPSB-15-408
Date: October 23, 2015

Attention: Nissan Sales, Service and Parts Managers

Nissan 4G WiFi & Apps

With Nissan 4G WiFi & Apps kits currently shipping to Nissan Dealers, Accessory Sales & Marketing is pleased to provide supporting marketing material for this all-new accessory.

Included in this Bulletin

- Nissan 4G WiFi & Apps Video Overview
- Marketing Support Material
- NissanWiFi.com Website Launch
- Live Presentation and Support from AutoNet
- Installation Instructions (near the end)

WiFi Highlights and Features

- 4G enables you to seamlessly and securely connect to the internet
- Works while the vehicle is stationary or moving
- Connecting up to 5 WiFi-enabled devices
- Available 1GB and 5GB affordable monthly plans

Additional App Services

Monitor the location and safety of the driver, passenger, and vehicle assets with the following apps:

- Parental Controls
- Find My Car
- Geo Zone Alerts
- Speed Tracker
- Curfew Alerts
- Valet Mode

Applicable Nissan Vehicles

- Versa Note
- Sentra
- Altima
- Maxima
- Rogue
- Murano
- Pathfinder
- Titan

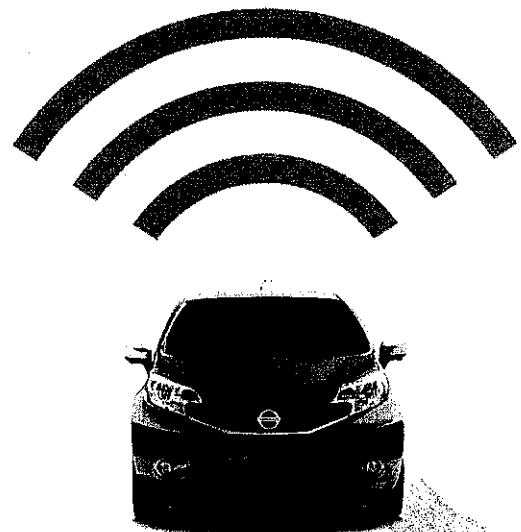

NISSAN ACCESSORY SALES & MARKETING



GENUINE NISSAN ACCESSORIES

Nissan 4G WiFi & Apps

Marketing Support Bulletin

Reference: NPSB-15-408
Date: October 23, 2015

Attention: Nissan Sales, Service and Parts Managers

Nissan WiFi & Apps FAQs

HOW DO I ACTIVATE THE NISSAN WiFi POWERED BY AUTONET MOBILE?

Login using a desktop or mobile device to activate online at www.nissanwifi.com/product/activation or at <https://signup.autonetmobile.com>. Simply enter your basic information and Serial Number found on the Activation Card supplied in your glove box.

HOW MANY USERS CAN BE CONNECTED TO WiFi BY AUTONET MOBILE SERVICE?

Up to 5 users can be connected to an Autonet Mobile connection.

HOW DO I CONNECT A WIRELESS ENABLED DEVICE TO THE ROUTER?

Search for a network on your wireless device and connect to a wireless network that contains the name Autonet (e.g. Autonet 1234). When a connection to the router has been established you may access the Internet from your wireless device.

IS THE WiFi SYSTEM PASSWORD PROTECTED?

Yes, Nissan WiFi powered by Autonet Mobile can be set up with password protection. Visit www.nissanwifi.com/product/activation and download the User Guide to learn about password setup and configuration.

WHAT IS THE WiFi RANGE FROM THE VEHICLE?

WiFi ranges 50 to 100 feet from the vehicle. The range varies depending on the surrounding interference and obstructions in the signal path.

WILL THE WiFi BY AUTONET MOBILE WORK IN MY AREA?

Autonet Mobile's service runs on the largest nationwide 4G LTE network available in the United States. Our coverage map is available on the website at www.nissanwifi.com at the footer of the page and click the "View Coverage Map" link to view the full coverage map.

HOW MUCH DOES THE WiFi SERVICE COST?

WiFi subscriptions start at \$19.95 for a 1GB plan and \$59.95 for 5GB plan per month.

CAN I MONITOR HOW MUCH DATA IS USED ON A MONTHLY BASIS?

You may monitor usage by logging into the My Account on www.nissanwifi.com or at <https://my.autonetmobile.com>. You can set and receive notifications when the monthly plan limit is reached.

WHICH WiFi DEVICES WORK WITH AUTONET MOBILE SERVICE?

All WiFi enabled devices work, i.e. smartphones, tablets, laptops, desktop computers, etc.

WHAT APPLICATIONS ARE AVAILABLE THAT WILL HELP ME CONNECT WITH MY VEHICLE?

Available Apps include Curfews, Find My Car, Geo Zones, Parental Controls, Speed Tracker and Valet. For more information visit www.nissanwifi.com/apps

IS A SERVICE CONTRACT REQUIRED?

No service contract is required. However we offer yearly subscription plans for a discounted rate.

DOES THIS SERVICE WORK IN OTHER COUNTRIES?

Service is currently available in the continental United States, Alaska and Hawaii.

WILL THE WiFi WORK WITH MY EXISTING CELL PHONE CARRIER?

Nissan WiFi is powered by Autonet Mobile, Inc., which is an independent internet service and Cloud solution provider.

DOES THE BATTERY DRAIN ON ACCESSORY MODE IF USING THE WiFi FOR A LONG PERIOD OF TIME?

Autonet Mobile offers a battery safe mode, when reaching low levels the Autonet Mobile system will shut off.



GENUINE PARTS

INSTALLATION INSTRUCTIONS

DESCRIPTION:	WiFi
APPLICATION:	Rogue
PART NUMBER(S)	T99Q8 4RA0A (Wifi kit)
REQUIRED FOR INSTALLATION:	999Q9-AY001 (Accessory Service Connector) - Not Included in T99Q8 4RA0A (Wifi kit)
KIT CONTENTS:	

Item	Qty.	Part Description	Service Part Number
A	1	WiFi TCU Module	T98Q8 4RA0A
B	1	Wire Harness	T98Q8 4RA1A
C	1	Activation Card	
D	8	10" Cable Ties	
E	8	Foam Tape 1" x 3.5"	
F	3	Posi-Taps	999M1 VT000
G	2	Alcohol wipe	
H	1	Two Sided Foam Tape	
I	5	Pet clear Tape 1" x 4"	
J	1	II Replacement Template	
K	1	Glove Box Brochure	

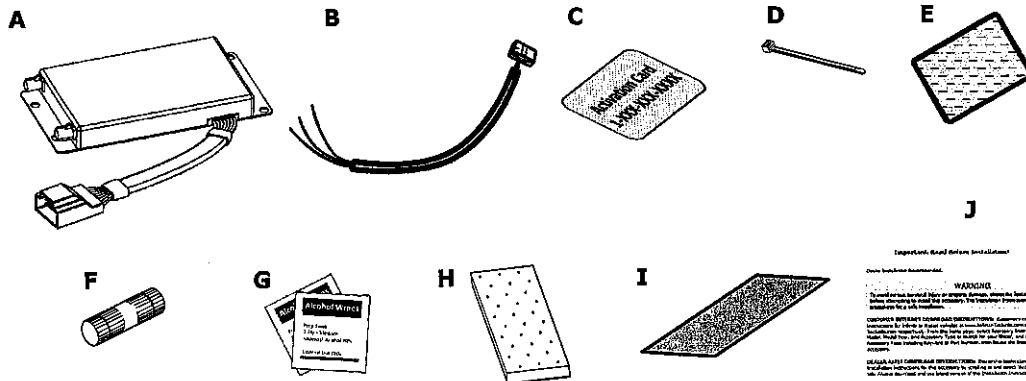

Important: Read Before Installation!

WARNING:

To avoid serious bodily injury or property damage, always use the correct installation technique. Always disconnect the battery before working on the vehicle's electrical system.

CAUTION: DO NOT REMOVE THE BATTERY COVER. The battery cover is not to be removed. The battery cover is not to be removed. The battery cover is not to be removed.

©2015 Nissan North America, Inc. All rights reserved. Nissan North America, Inc. is not responsible for any damage or injury caused by the use of this product.

999Q9 AY000 (ACCESSORY SERVICE CONNECTOR) - SERVICE PART

Item	Qty.	Part Description	Service Part Number
AA	1	Accessory Service Connector (NOT INCLUDED IN KIT)	999Q9-AY001



Note: 1 or 2 ASC (Accessory Service Connector) may already be installed in the vehicle.

TOOLS REQUIRED:

- #2 Phillips Screwdriver
- Nylon Trim Tool
- Wire Cutter
- Flashlight
- 10mm Socket
- Ratchet

Vehicle Preparation:

⚠ CAUTION

• Always confirm the ignition is in the "OFF" position before changing the switch condition.

- 1) Apply parking brake
- 2) Confirm vehicle is not in the default shipping state or "Inventory position" as shown below. Failure to confirm vehicle has been removed from this state will result in loss of normal vehicle operation.
- 3) Locate Extended Storage Switch in cabin fuse block. Confirm it is in the "Customer" position. See below for reference.

a) To remove transit mode (Fuse Block):

1. Remove fuse cover lid.
2. Push down shorting pin.
3. Ign On 2 times without starting the vehicle.

b) To remove transit mode (BCM):

1. Confirm ignition switch is in "OFF" position.
2. Simultaneously push the signal and wiper switch fully down for two (2) seconds.

NOTE: While in BCM Transit Mode, turn signal indicators will remain illuminated for one minute.

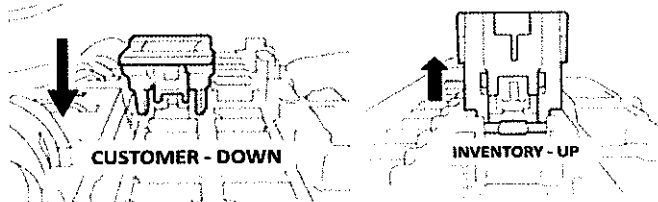
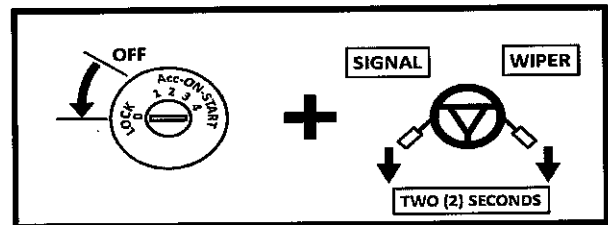
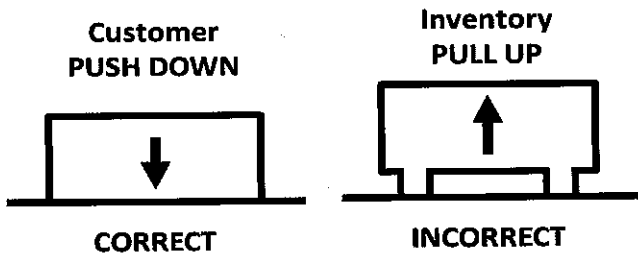

c) To return to transit mode for storage:

1. Ign Off.
2. Remove fuse cover lid.
3. Pull up shorting pin.
4. Assemble fuse cover lid.
5. Ign On 2 times without turn the vehicle on.
6. Confirm transit mode condition on meter

NOTE: Typical vehicle condition shown above. Switch is easily identifiable by the permanent, push-pull fuse holder. Actual position on the fuse block may vary, vehicle to vehicle.

Condition	Switch Position	Note
Vehicle is delivered to the dealer	Inventory Condition	
Technician performs PDI	Customer Delivery	Return to Inventory position after PDI.
Customer test drives the vehicle	Customer Delivery	Return to Inventory position after test drive.
Vehicle is being stored at the dealer	Inventory Condition	
Vehicle is delivered to customer	Customer Delivery	

NOTE: The Extended Storage Switch is only an aid to improve battery life during vehicle storage at the dealer. If the Extended Storage Switch fuse ever needs service after vehicle delivery, discard the Extended Storage Switch and install the correct fuse in its place.

- 4) Turn ignition switch to "ON" position
- 5) Record the customer radio presets and other presets as required.

Preset	1	2	3	4	5	6		

- 6) Put shift lever in "P" position for A/T and CVT or "1st" for M/T
- 7) Turn ignition switch to "OFF" position
- 8) Use seat and floor protection.

INSTALLATION PROCEDURE: PRE-INSTALLATION CAUTIONS / NOTES

CAUTION

Allow 5 min after for off and doors closed for vehicle to time out. Allow an additional 5 min after negative terminal disconnect before separating any electrical connectors.

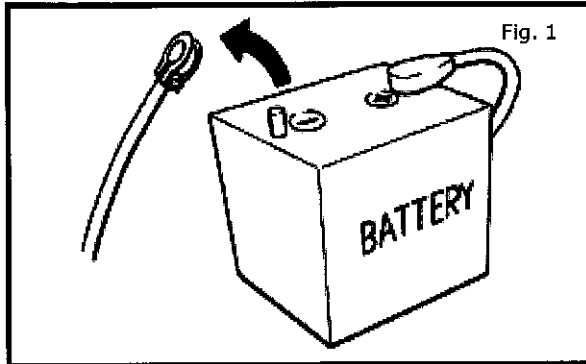

- 7) Disconnect the negative battery terminal as shown in Fig. 1.
- 8) Use seat and floor protection.
- 9) This part is to be installed at surface temperature of 65-100 deg.F.

CAUTION

- Take care not to scratch or damage any component during the removal or reinstallation process.
- Trim pieces found to have witness marks or broken clips are not to be reinstalled.
- Additional trim in cargo area may need to be removed.
- Always remove vehicle parts in the sequence they are shown. Improper procedure can damage parts.
- Store removed parts in a safe and protected manner.

INSTALLATION OVERVIEW:

1.) SYSTEM

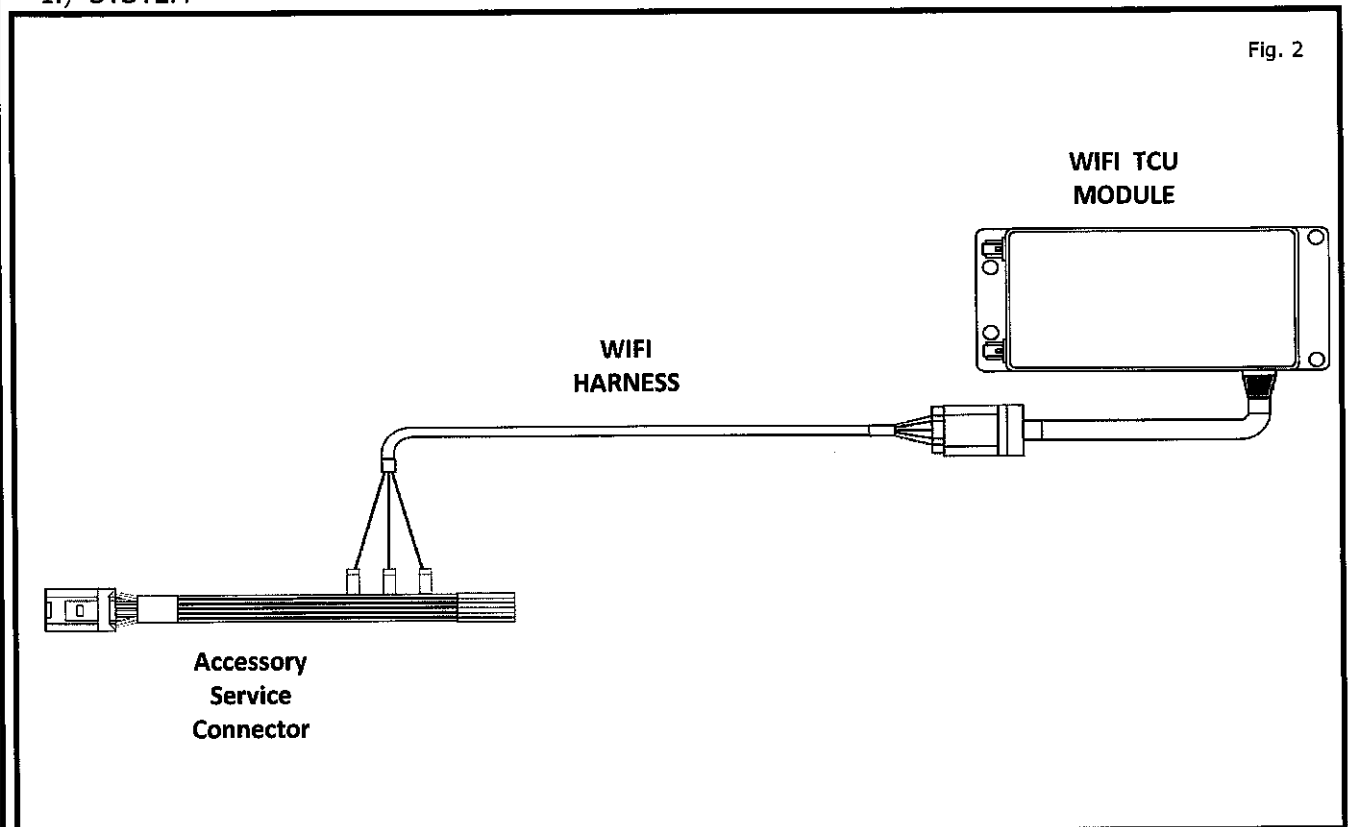

INSTALLATION OVERVIEW:

2.) VEHICLE

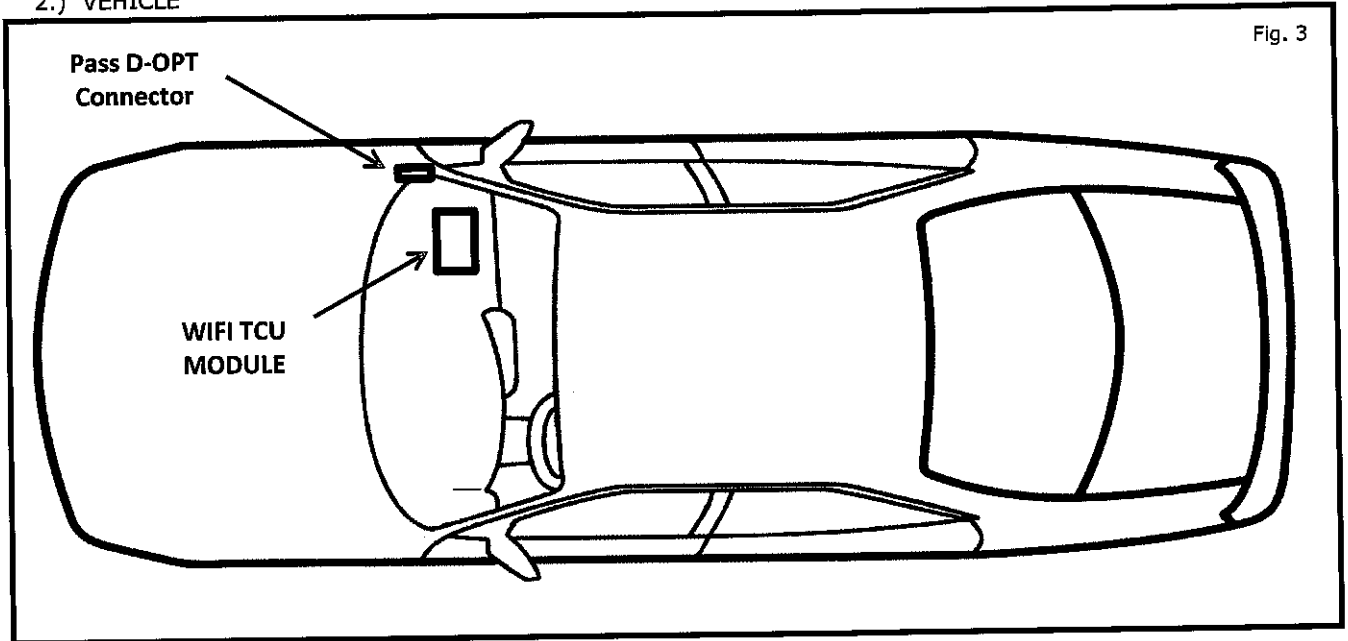

CAUTION

- Any description of vehicle wiring color is for reference only.
- Always refer to vehicle wiring diagram for details.

3) Routing

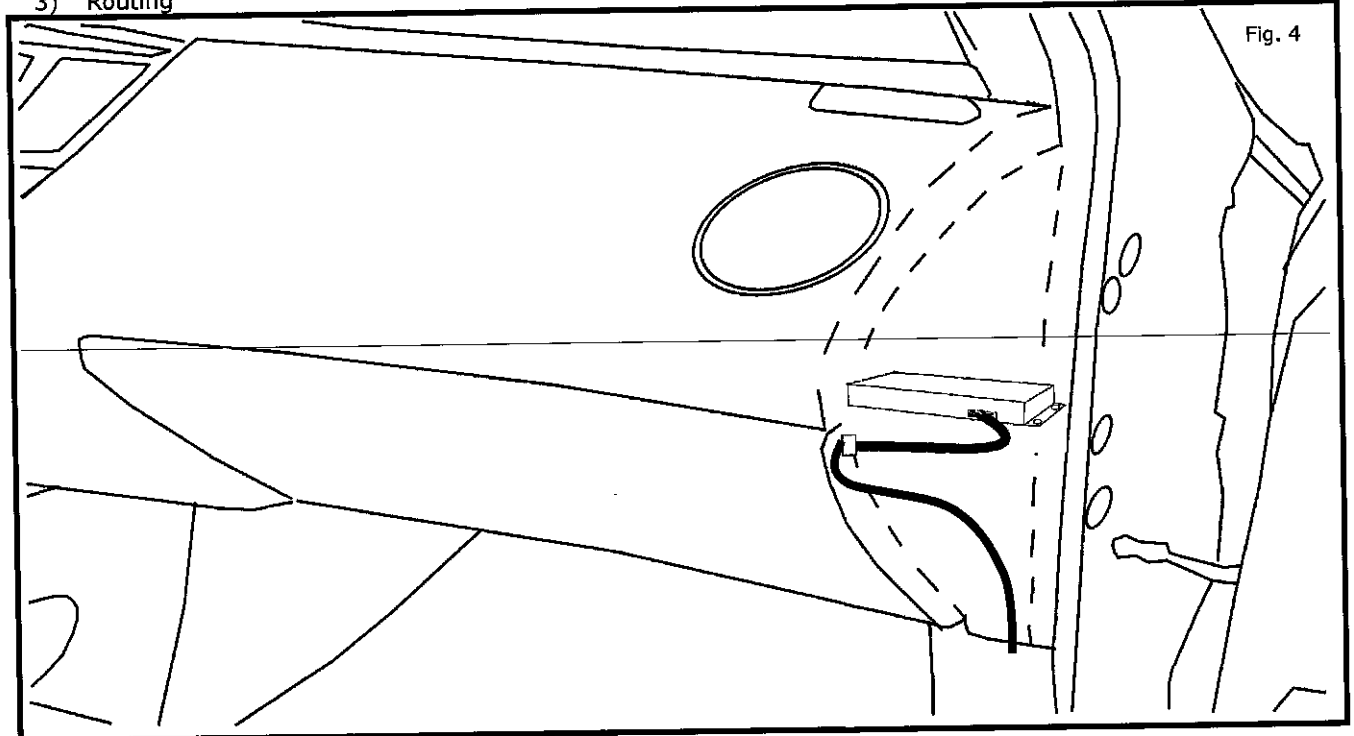

INSTALLATION PROCEDURE:

VEHICLE PARTS REMOVAL

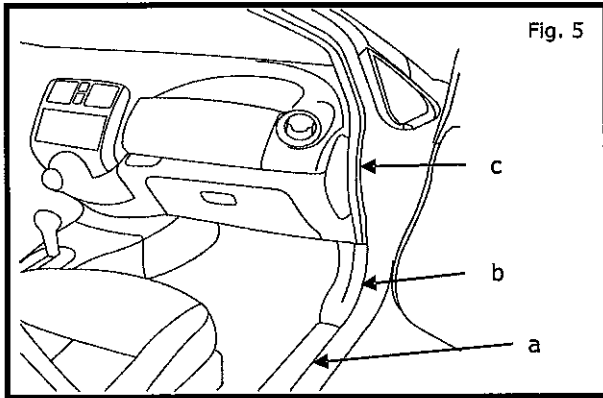

Fig. 5

- 1) Removing items as follows:
 - a) Passenger Kick Plate.
 - b) Passenger Kick Panel.
 - c) Passenger side dash mask

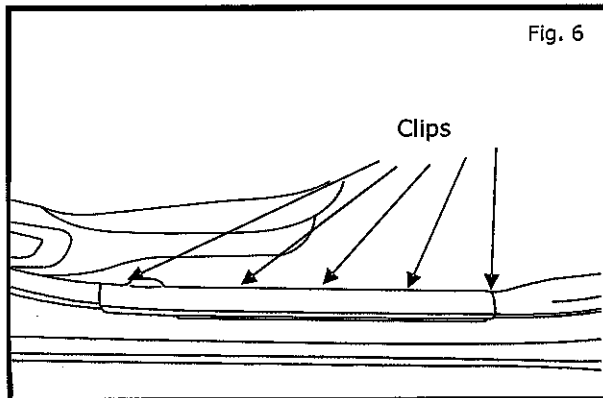

Fig. 6

- 2) Removing passenger kick plate.

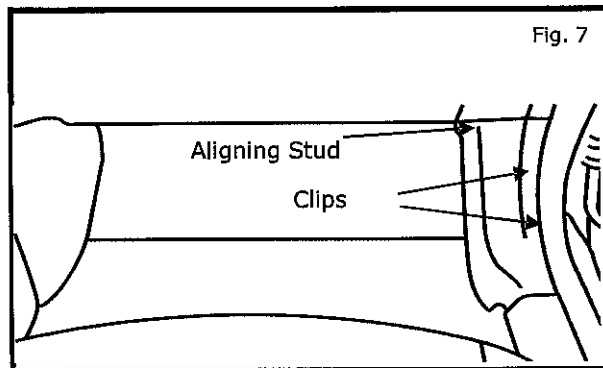

Fig. 7

- 3) Removing passenger kick panel.

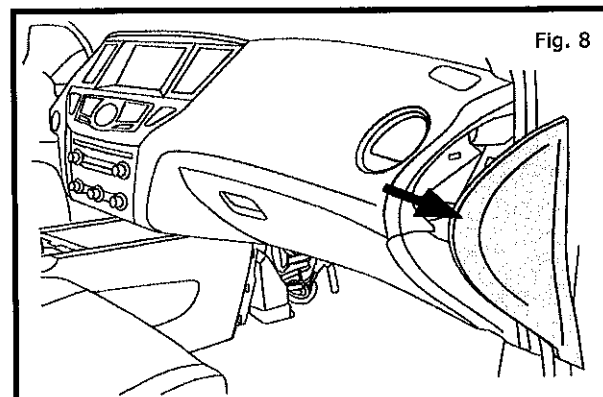
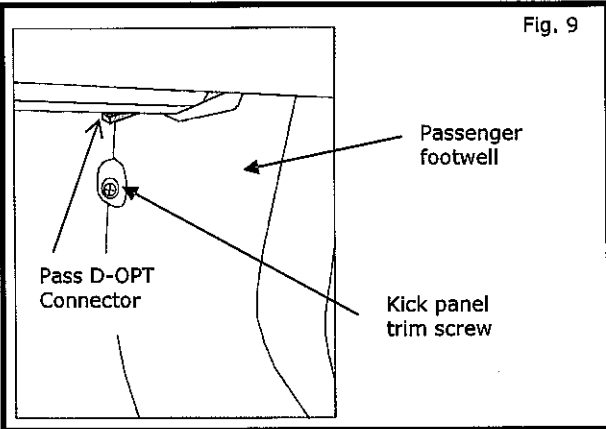

Fig. 8

- 4) Removing dash mask.
 - a) Carefully pry off passenger side dash mask as shown using a nylon trim tool.

INSTALLATION PROCEDURE: VEHICLE PARTS REMOVAL



- 5) Locating Passenger D-OPT Connector
- a) Locate passenger side D-OPT Connector on right side of the footwell as shown in Fig. 9. Cut Pass D-OPT connector cable tie to access the connector.

- b) **Positap after step 28a). Go to step 22 now.**

Note:

1.) If there is already an Accessory Service Connector in passenger side read step 6, if not proceed to step 7.

2.) If there is not an Accessory Service Connector in passenger side remove dummy plug in connector.

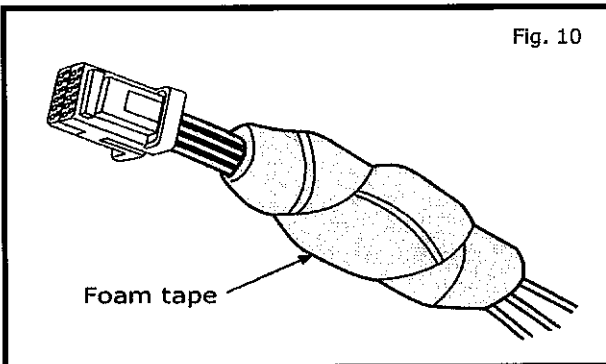

- 6) Locating Accessory Service Connector
- a) If there is already an Accessory Service Connector in passenger side remove it before continuing.

- b) Remove any foam tape present before adding any positaps as shown in Fig. 10.

Note: □

If there is not an Accessory Service Connector present in passenger side connector order from service dept.

999Q9 AY001

Pin	Label	Color
1	IGN	WHITE
2	BAT	RED
3	TL LMP	PURPLE
4	RM LMP	YELLOW
5	BATSVR	PINK
6	FR DR SW RH	GREEN
7	FR DR SW LH	LT GREEN
8	THRU SIGNAL 1	GREY
9	RR DR RH	BLUE
10	RR DR LH	LT BLUE
11	ACC	ORANGE
12	GND	BLACK

Fig. 11

Pin location is referenced looking from the harness side of connector.

1	2	3	4	5	6
7	8	9	10	11	12

- 7) Accessory Service Connector Reference

- a) Accessory Service Connector pin out is shown in Fig. 11.

Note:

1.) For direction on how to posi-tap refer to steps 11 - 21.

2.) For additional circuit information refer to the mech drawing at the end of the installation instructions.

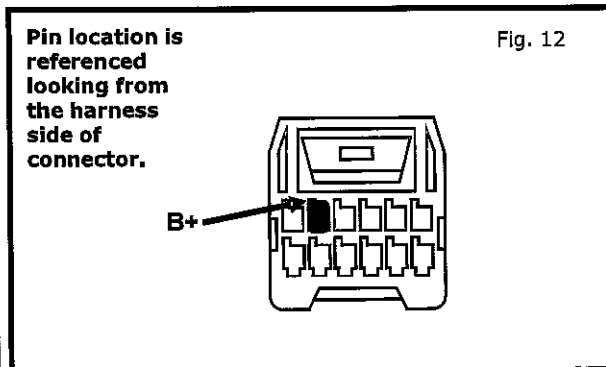

- 8) Positap B+

- a) Tap **Red** wire on WiFi TCU Module harness to Red (B+) wire on Accessory Service Connector as shown in Fig. 12.

INSTALLATION PROCEDURE: POSI-TAP

Pin location is referenced looking from the harness side of connector.

Fig. 13

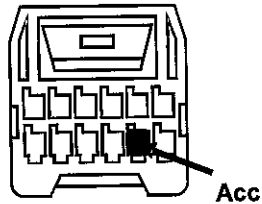

Pin location is referenced looking from the harness side of connector.

Fig. 14

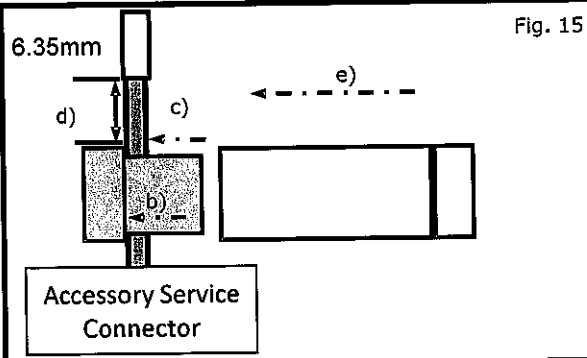
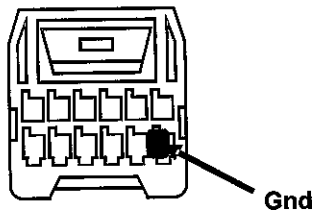

Fig. 15

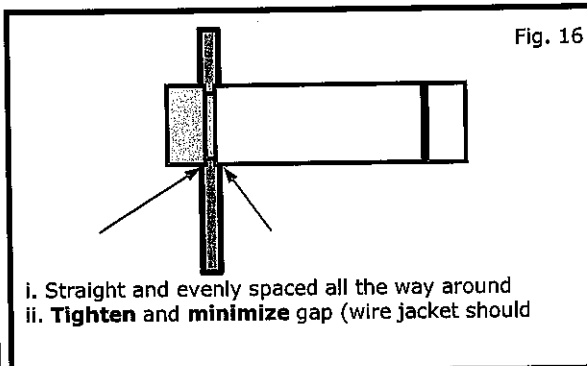

Fig. 16

- 9) Positap ACC
 - a) Tap the **White** wire on the WiFi TCU Module harness to the Orange (Acc) wire on the Accessory Service Connector as shown in Fig. 13.
- 10) Positap GND
 - a) Tap **Black** wire on WiFi TCU Module harness to Black (Gnd) wire on Accessory Service Connector as shown in Fig. 14.

NOTE: Figures are not to scale.

- 11) Posi-tapping an Accessory service wire (Fig. 15)
 - a) Identify and confirm correct wire in Accessory Service Connector to be tapped.
 - b) Remove cap (slot side) from tap body.
 - c) Slide cap around single accessory wire.
 - d) Position cap $\geq 6.35\text{mm}$ (0.25in) away from the heat shrink end of Accessory Service Connector (measurement for first posi-tap installed on the circuit).
 - e) Tighten tap **TIGHT** with finger pressure.
 - f) Tighten by another quarter turn.
- 12) Inspecting tap for correct installation (Fig. 16).
 - a) Pull on wire lightly to ensure connection.
 - b) Inspect tap to ensure correct installation.
 - c) Test signal to ensure that it is working properly.

NOTE:

Avoid putting pressure on the vehicle wire and tap for the remainder of the installation.

INSTALLATION PROCEDURE: POSI-TAP

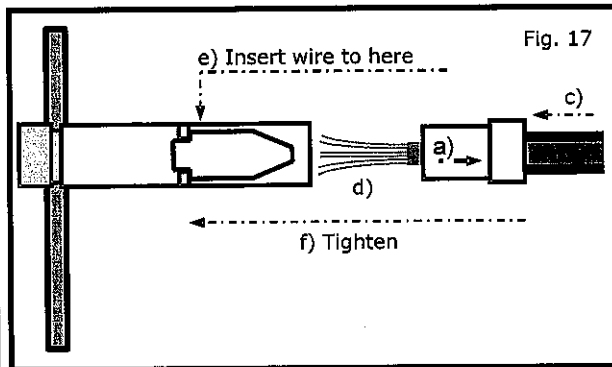

- 13) Tap accessory wire (Fig. 17).
 - a) Remove tap (non-pierce) side from tap.
 - b) Remove the protective stub from wire.
 - c) Insert wire through non-pierce side opening.
 - d) Spread the individual strands into fan shape.
 - e) Insert wire into tap body and ensure that it is all the way in.
 - f) Tighten tap **TIGHT** with finger pressure.
 - g) Tighten by another quarter turn.

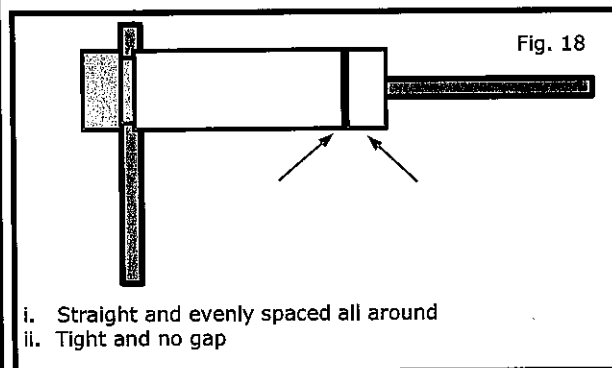

- 14) Confirm tapped accessory wire.
 - a) Pull on wire lightly to ensure connection.
 - b) Inspect tap to ensure correct installation as shown in Fig. 18.

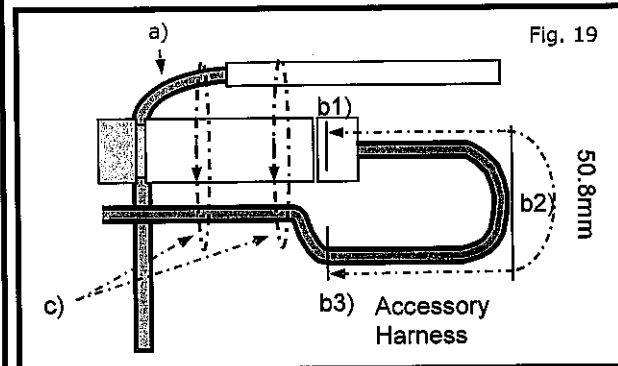

- 15) Forming strain relief loop - required (Fig. 19).
 - a) Gently bend end of pierced wire (where it exits cap) down towards body of posi-tap.
 - b) On tapped wire of non-pierce side; starting at point b1), measure 50.8mm(2in) to point b3). Make first bend of loop b2), half distance measured 25.4mm(1in), and up toward body of posi-tap, make second bend of loop b3).
 - c) Secure pierced wire on heat shrink side and tapped wire on non-pierce side to body of tap with electrical tape (≥ 2 revolutions).

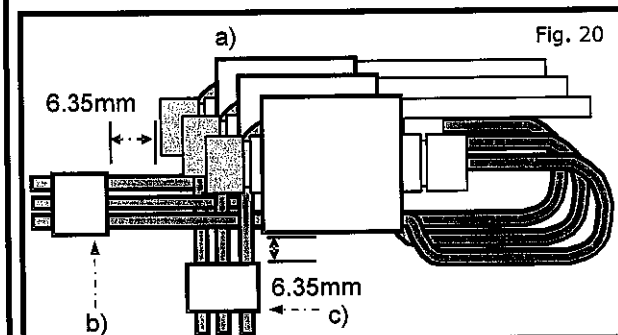

- 16) Securing multiple accessory taps (Fig. 20).
 - a) Tapped accessories (wires already secured to tap bodies) are stacked slightly staggered on top of each other as shown in Fig a).
 - b) Tapped wires on non-pierce side of all posi-taps are secured to each other with electrical tape (≥ 2 revolutions) at a distance of $\geq 6.35\text{mm}$ (0.25in) as shown in Fig b).
 - c) Pierced wires of first and subsequent posi-taps are secured to each other with electrical tape (≥ 2 revolutions) at a distance of $\geq 6.35\text{mm}$ (0.25in) as shown in Fig c).

INSTALLATION PROCEDURE: POSI-TAP

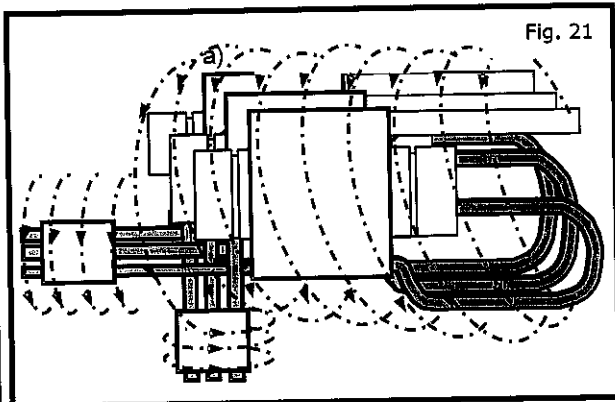

- 17) Pre- foam protective wrap
- Starting at heat shrink; firmly wrap posi-tap bundle with electrical tape or non-adhesive wire harness tape, making sure to overlap the previous revolution as shown in Fig. 21.

Note:

If using a non adhesive tape to wrap the bundle, secure at both ends with ≥ 2 revolutions adhesive electrical tape.

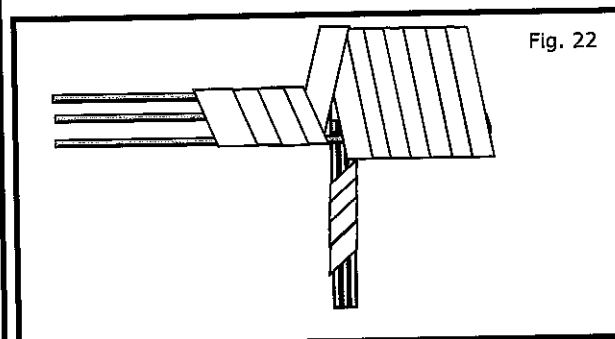

- 18) Finished protective wrap
- Make sure finished wrap looks similar to Fig. 22.

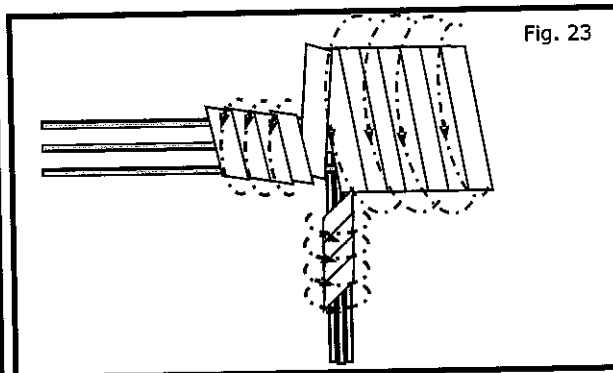

- 19) Foam wrap for posi-tap bundle (foam strips)
- Wrap posi-tap bundle with foam tape, following a pattern similar to the electrical tape, making the best use of foam strips provided as shown in Fig. 23.

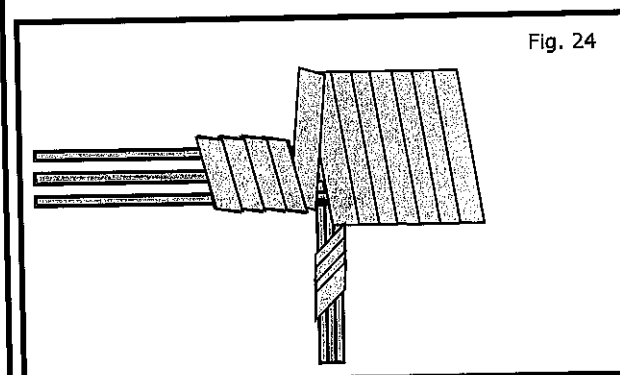

- 20) Finished foam wrap for bundle (strips-top view)
- Make sure finished wrap looks similar to Fig. 24.

INSTALLATION PROCEDURE: POSI-TAP

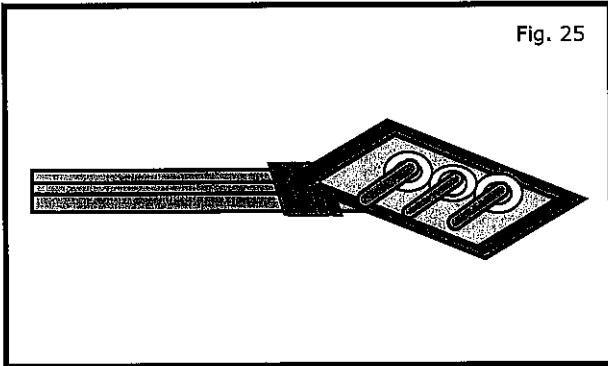

- 21) Finished foam wrap for bundle (strips-side view)
- Make sure the finished wrap looks similar to what is shown in Fig. 25.

CAUTION

This Accessory Service Connector is for use only with Genuine Nissan (or Infiniti) or Nissan (or Infiniti) approved accessories. Use of this connector with non Genuine Nissan (or Infiniti) or Nissan (or Infiniti) approved accessories or failure to follow the installation instructions for the connector contained in this package may result in damage to the accessory and/or your vehicle. Nissan (or Infiniti) is not liable for loss or damage due to improper installation or the installation of non Genuine or non approved accessories.

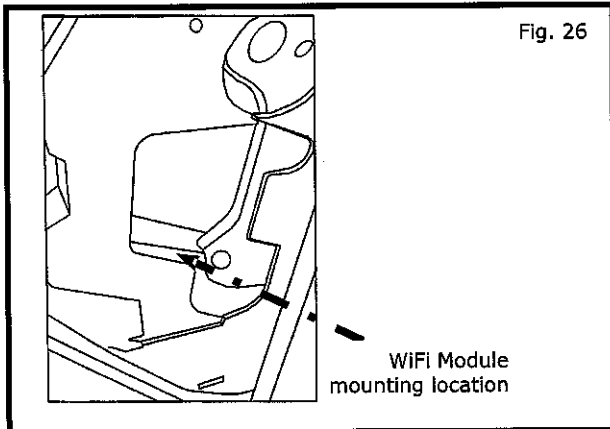

- 22) Prepping surface for mounting WiFi module.
- Clean glove box installation surface and WiFi base plate with an alcohol wipe.

WiFi mounting location is inside side dash mask area.

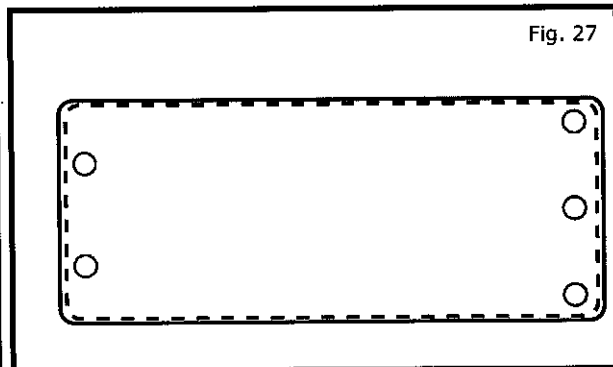

INSTALLATION PROCEDURE: WIFI MODULE

Fig. 28

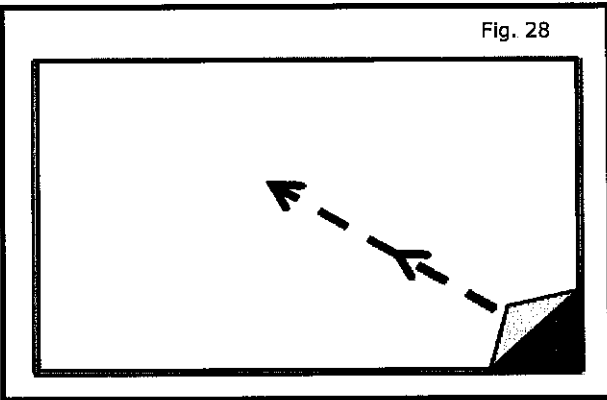

- 23) Module Installation
a) Peel tape liner off of adhesive square as shown in Fig. 28.

Fig. 29

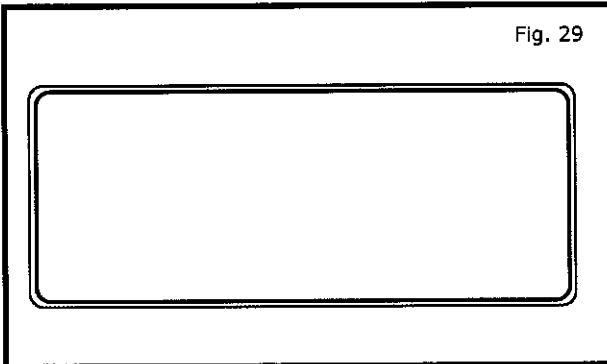

- 24) Module Installation
a) Apply double sided tape to base plate of WiFi module as shown in Fig. 29.

Fig. 30

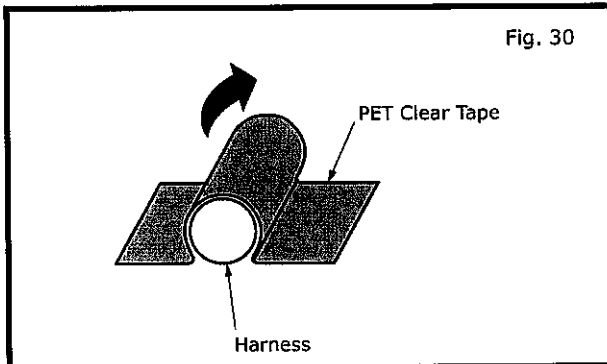

NOTE:
When taping PET clear tape to glove box, ensure tape is wrapped up and over harness as shown in Fig. 30.

Fig. 31

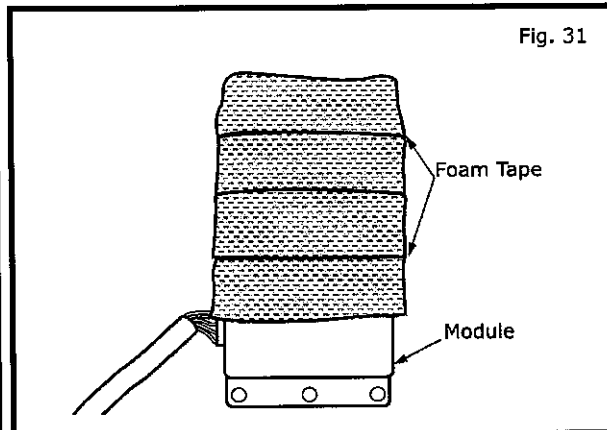

- 25) Module Installation
Wrap module on top with foam tape as shown.

INSTALLATION PROCEDURE: WIFI MODULE

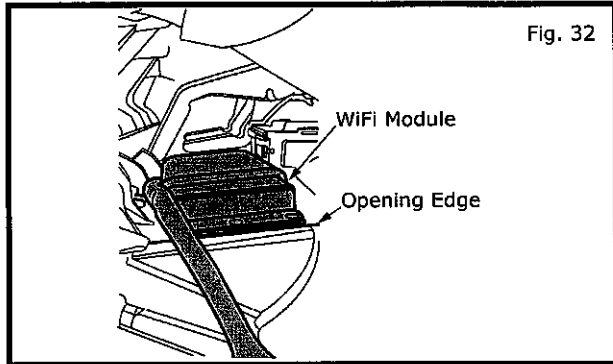

- 26) Module Installation
Place WiFi module inside opening, behind dash mask; and line with edge of opening. **Line up before taking off tape liner.**

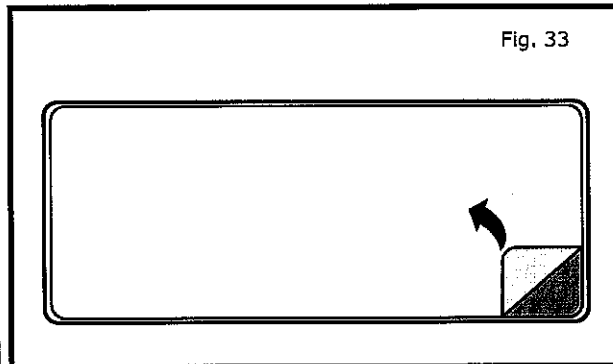

- 27) Module Installation
- Peel tape liner from foam pad on module as shown in Fig. 33.
 - Carefully place module with paper liner off in same position as in step 26. Press WiFi module to opening with 15lbs min. pressure.

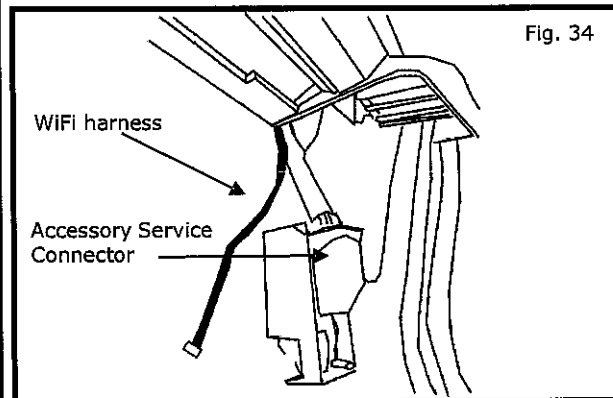

- 28) Module Installation
- Connect WiFi harness to WiFi module. Route harness down inside opening in side mask area to Pass D-OPT Connector located in passenger kick well area.
 - Positap per instructions steps 6 - 21. If no other Accessory Service Connector is present, may positap first and feed ASC down side mask area.
Foam wrap positaps on ASC.

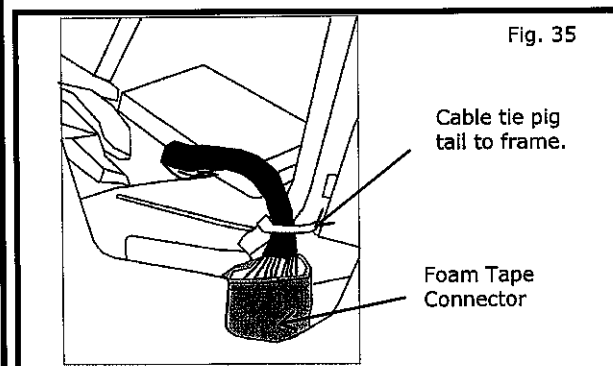

- 29) Module Installation
Foam wrap pig tail male connector to prevent rattling. Cable tie pig tail connector to frame as shown.
Push connector to inside.

FINAL INSPECTION:

⚠ CAUTION

Use caution when re-installing interior components to avoid damage, scratches, or breaking of mounting clips. Refer to the vehicle service manual for more information.

- Inspect the installation area for any debris.
- Make sure all trim clips are in their retainers and gently press the trim panels into place.
- Verify re-installed trim parts for proper flush fit (no gap, no waviness, etc.).
- Verify all clips are fully engaged and locked.
- Verify re-installed trim parts are free from cracks, scratches or stress marks.
- Verify vehicle headliner, seat, steering wheel, center console, floor carpets, etc. are not soiled.
- Verify interior and exterior is not damaged.
- Connect the battery negative terminal and tighten the nut to 5.4 N-m (47.8 lb-in).
- Turn ignition switch to "OFF". Wait 10 seconds, then switch to "ON".
- Turn ignition switch to "ON" and confirm proper operation of vehicle systems and verify:
- Re-program radio presets and other vehicle settings to the recorded settings.
 - Confirm proper audio function (AM, FM, SAT, CD and AUX).
 - That there are no new Diagnostic Trouble Codes.
 - Verify all windows and sunroof (if equipped), one touch operation and perform the reset procedure if necessary. Refer to the vehicle service manual for more details.
 - Power Back Door (If equipped). - Turn on the car, push and note if trunk opens.
 - Tail Lamp - Turn on headlamps; open glove box and note whether light goes on.
 - Start vehicle. Note whether vehicle starts.
- Front Sonar Module Connector - Turn on vehicle, put vehicle in 'Drive'. Move slowly towards a large object in front of the vehicle. Note whether alarm sounds.
- Rear Sonar Module Connector - Turn on vehicle, put vehicle in 'Reverse'. Move slowly towards a large object behind the vehicle. Note whether alarm sounds.
- Place the Owner Manual, Quick Reference Guide, and/or other Manual in the glove box.

FINAL INSPECTION: CHECK OUT

- Turn your car to the ACC position to power up the WiFi module. Wait 3 minutes.
- Open your wireless network list and connect to "Autonet-XXXX" (The last 4 digits will be the last 4 digits of the WiFi serial number).
- Open your browser the following screen appears.

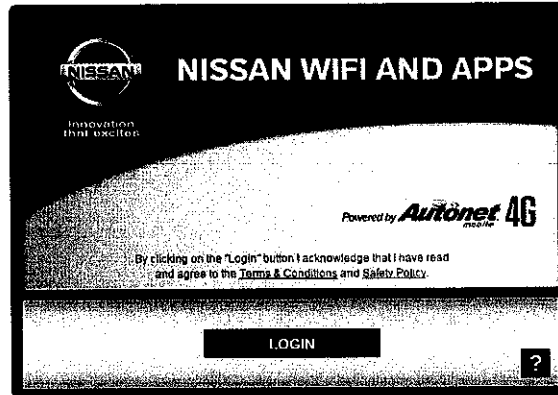

Autonet assumes no responsibility for the configurations, security, or data files on your wireless device resulting from connection to Autonet's network. Autonet's privacy, and security protection is the responsibility of the user.

Autonet Mobile recommends that the driver of this vehicle should not attempt to use this system while driving the vehicle.

Do not operate any function that takes your attention away from safely driving your vehicle. Any function that requires prolonged attention should be performed after coming to a complete stop. Always stop the vehicle in a safe location before performing these functions. Failure to do so may result in an accident.

Copyright © 2015 - 2015 AutonetMobile, Inc. All Rights Reserved.

- Click the LOGIN button. If the following screen appears showing no signal while trying to log in there is insufficient cell tower signal. The vehicle may have to be moved outside for better reception.

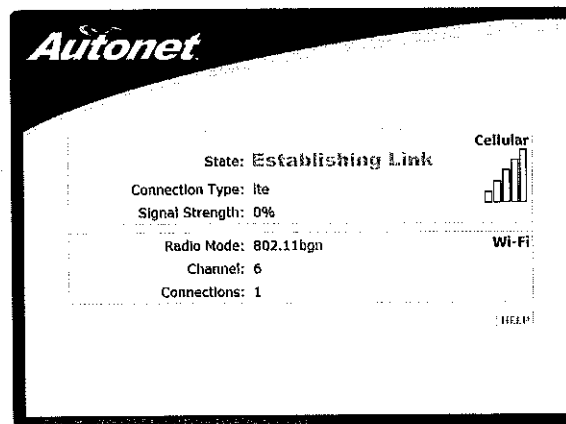

If you are unable to see the "Autonet-XXXX" in your wireless network list verify power is present to the WiFi module. If power is present and module still does not appear on the wireless network list call Autonet Mobile at 1-800-977-2107

FINAL INSPECTION: CHECK OUT

- After pressing the 'Login', the following window will open, the WiFi module is now in communication with the cell tower. Installation is complete.

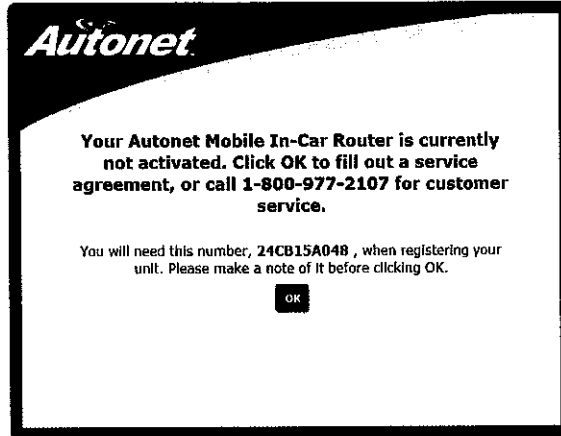

The test verifies data communication via network/telecommunication as indicated by prompting the user to fill out a service agreement.

If the service agreement does not pop up this indicates that the Telecommunications (WiFi/network) failed. Contact Autonet Mobile at 1-800-977-2107

- Place the Activation Guide, and glove box brochure in the glove box.

Posi-Tap™ is protected by patent # 5,228,875 5,695,369 5,868,589 6,692,313 Jap 2881414 Aus 708700 Tia 103534 Can 2204826 Mex 200626 Korea 477279 China Z197105562.9 & others pending.

WiFi

PASSENGER SIDE

ACCY_SER_CONN

IGN	1
BAT	2
TAIL_LAMP	3
ROOM_LAMP	4
BAT_SAVER	5
FR_DOOR_SW_RH	6
FR_DOOR_SW_LH	7
THRU_SIGNAL_1	8
RR_DOOR_RH	09
RR_DOOR_LH	10
ACC	11
GND	12

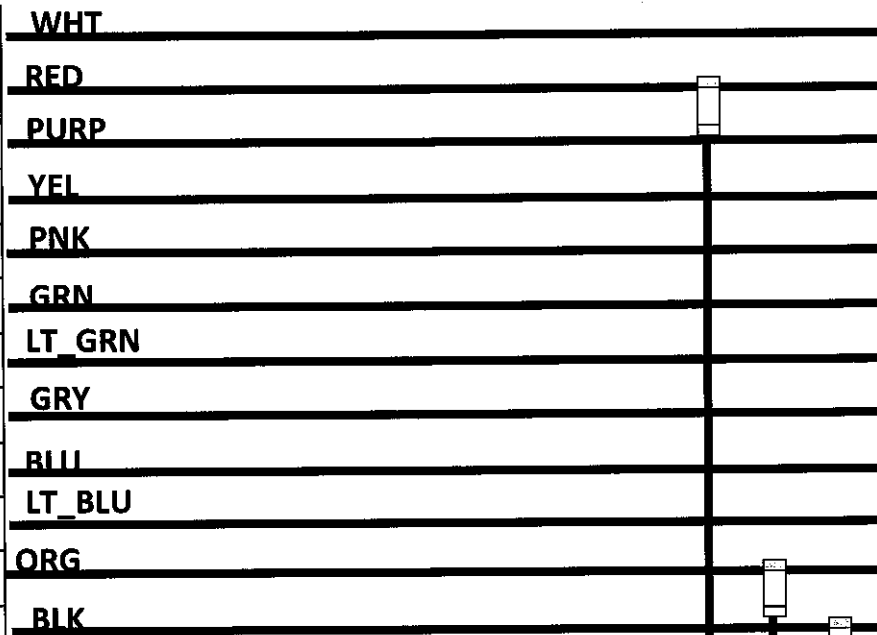

TH12FW-NH

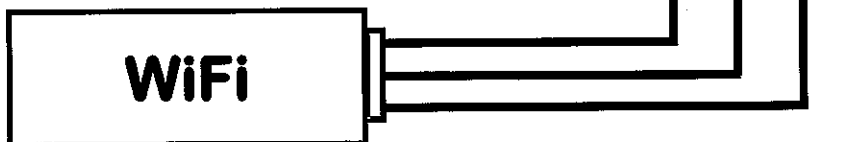
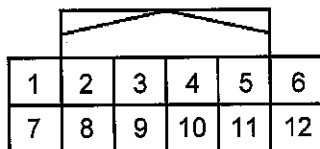

Note: Pin location is referenced looking into wire side of connector.

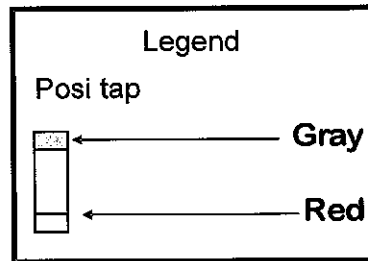

CAUTION

This Accessory Service Connector is for use only with Genuine Nissan (or Infiniti) or Nissan (or Infiniti) approved accessories. Use of this connector with non Genuine Nissan (or Infiniti) or Nissan (or Infiniti) approved accessories or failure to follow the installation instructions for the connector contained in this package may result in damage to the accessory and/or your vehicle. Nissan (or Infiniti) is not liable for loss or damage due to improper installation or the installation of non Genuine or non approved accessories.