

## VQ35DE Idler Pulley Delete

In this guide, we'll show you how to remove the extraneous "water pump" idler pulley found on earlier VQ35DEs. This can be accomplished at home with basic hand tools, no special equipment is required.

It helps to have the car in the air while working, so please make sure to take all necessary safety precautions while working around and under your vehicle. This guide is for instructional purposes only, and CZP cannot be held liable to any damage caused to person or property.

1. First, remove the cooling fan assembly. To do this, you will need to:
  - a. Disconnect the upper radiator hose (coolant will leak out, you can drain the radiator first to avoid spills if preferred).
  - b. Disconnect the fan motors (2x)
  - c. Remove the air box.

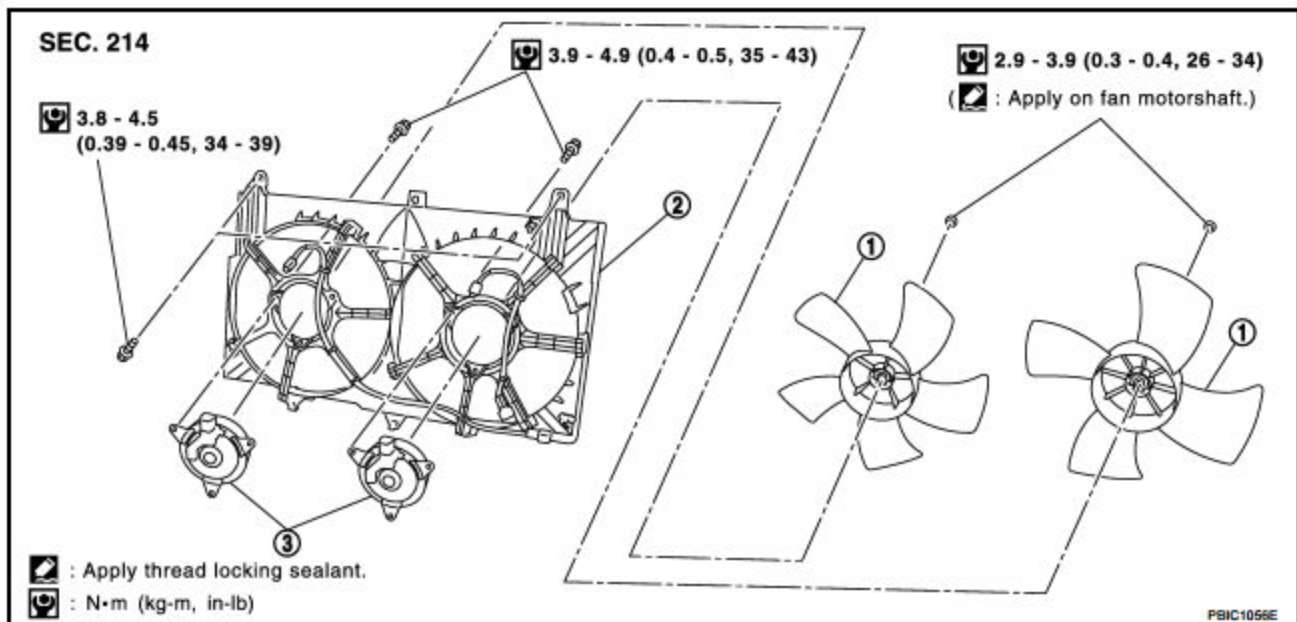

1. Cooling fan

2. Fan shroud

3. Fan motor

2. Remove the engine under-cover shroud. These are held in by several 10mm bolts.

3. This will give you access to the main tensioner pulley. Loosen the nut on the face of the pulley slightly, then loosen the tensioner bolt to relieve tension from the belt.

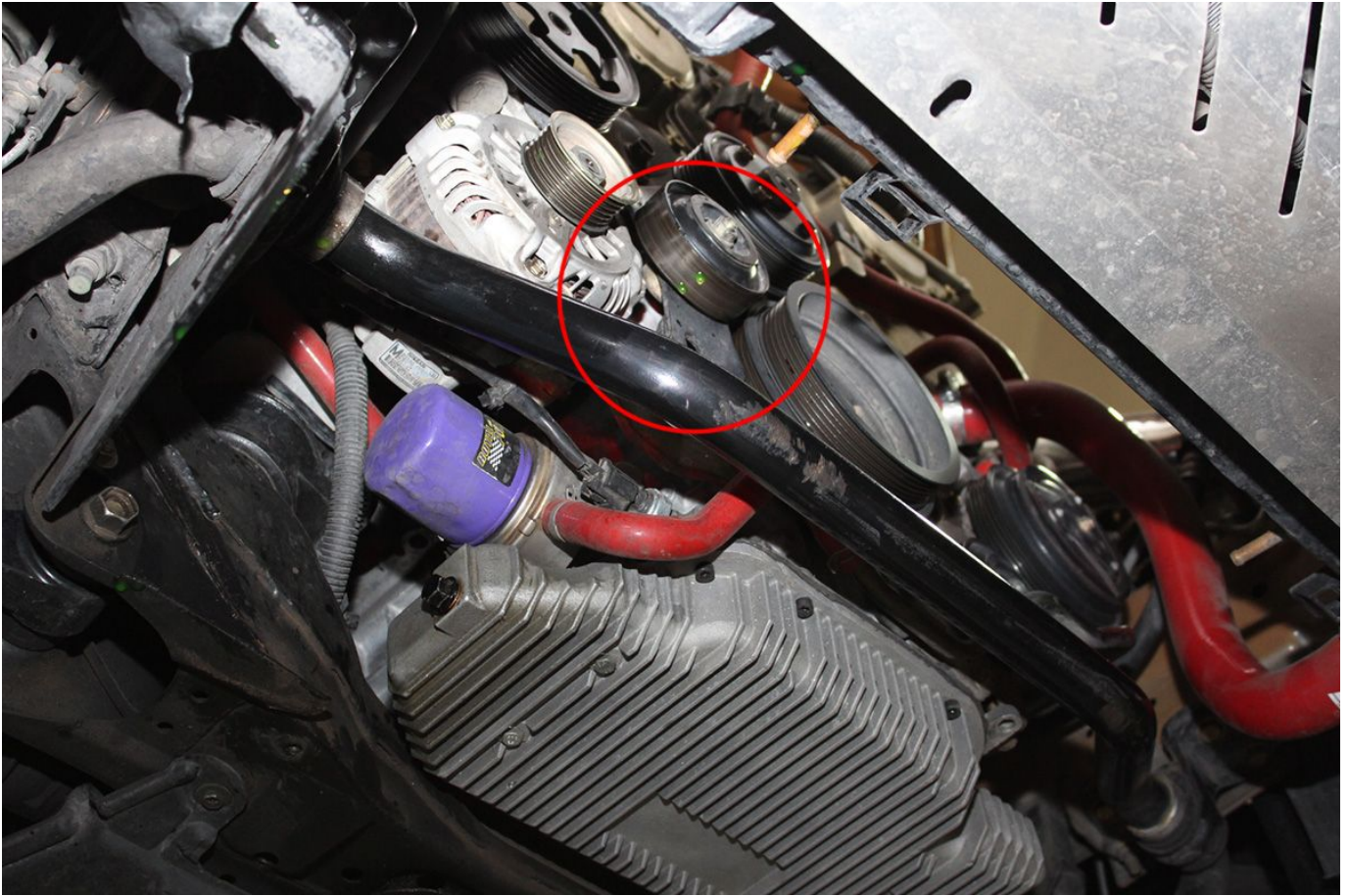

4. Moving to the top, this is the idler we will be removing. Remove the mounting bolts holding it in place, including the one that also secures the bracket in front of the idler's mount.

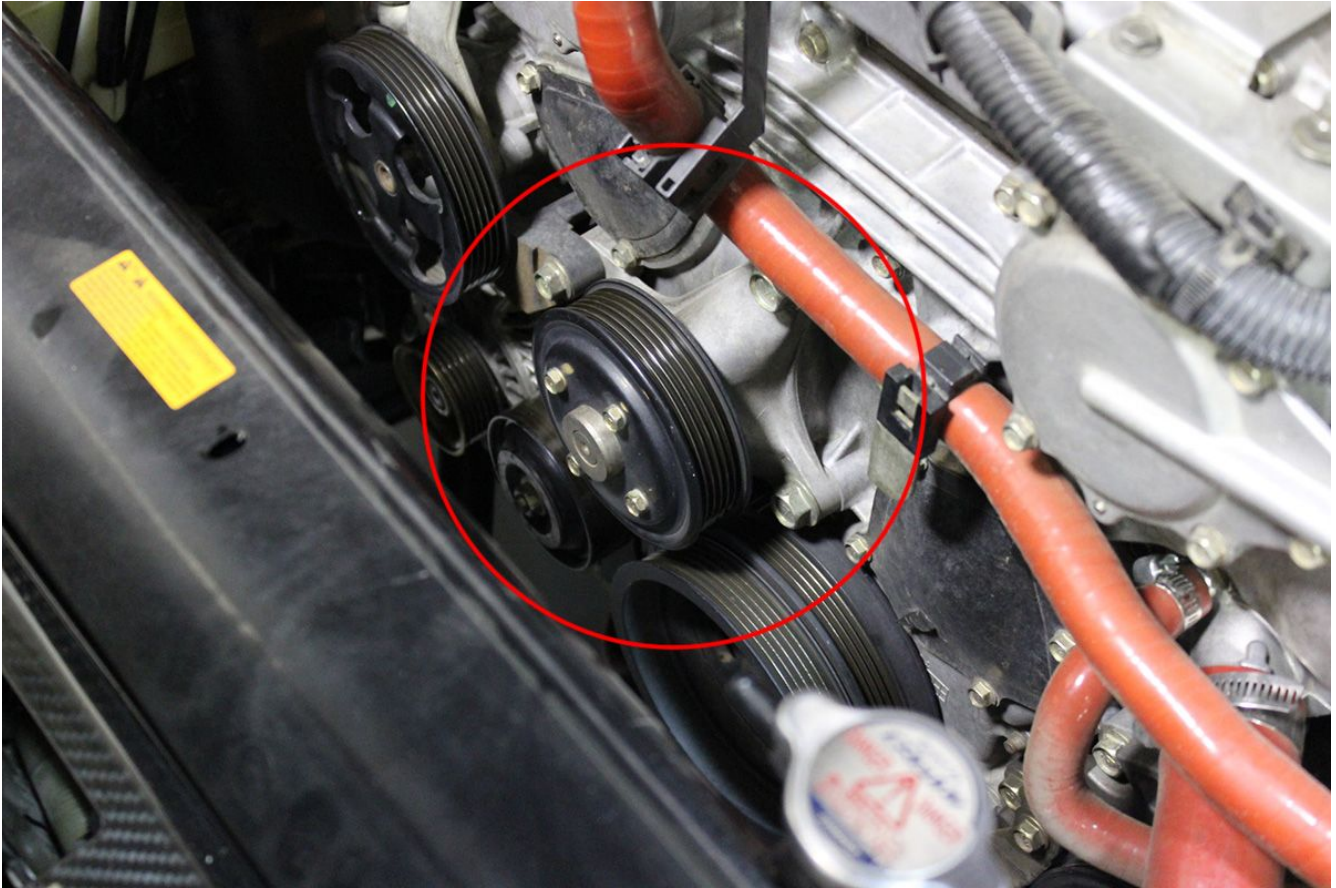

5. With the idler removed, you'll see the gap between the bracket and timing cover we need to fill in.

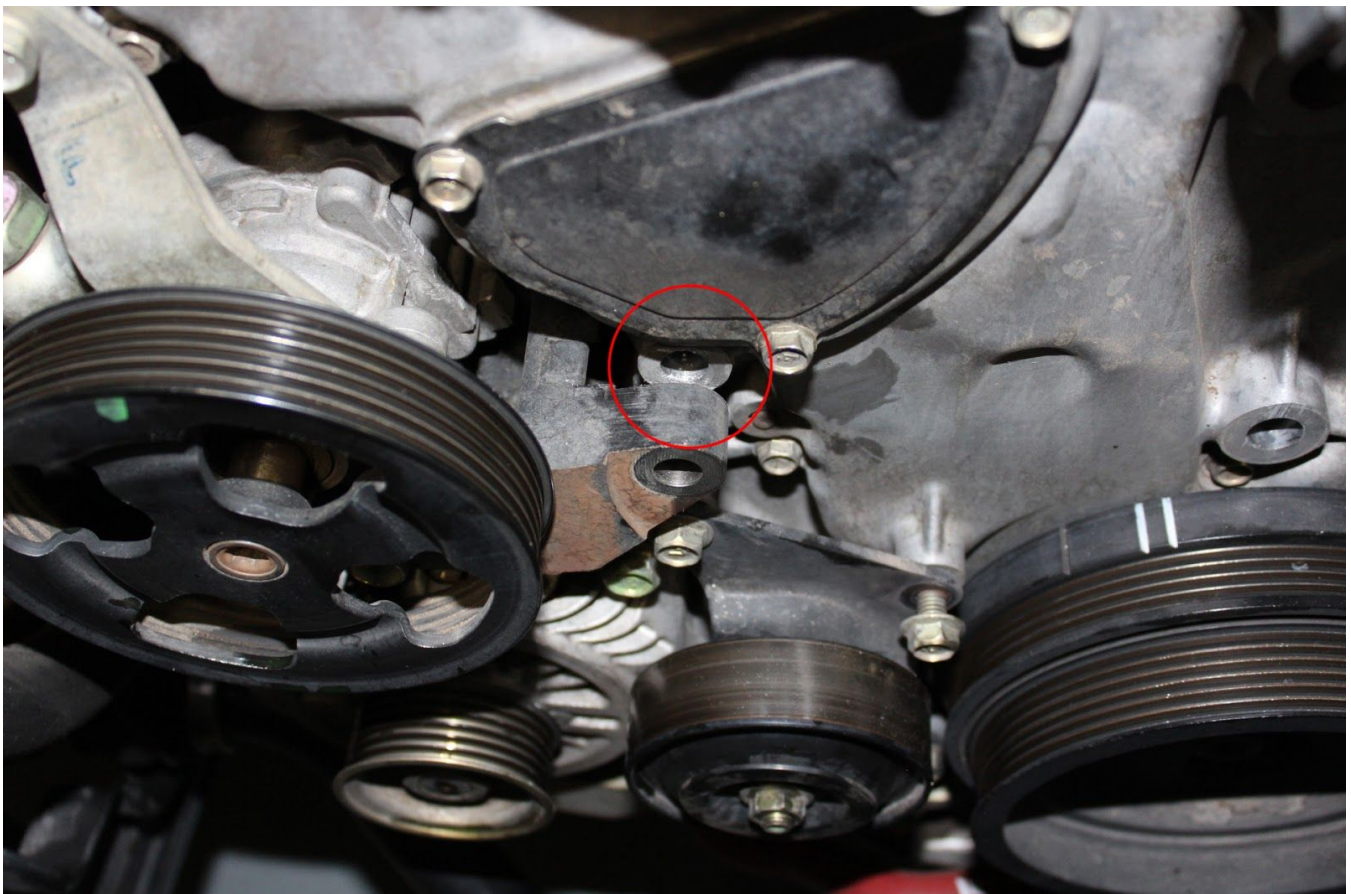

6. It helps to use a pry bar to pull the bracket outward just slightly and give yourself a little more clearance.

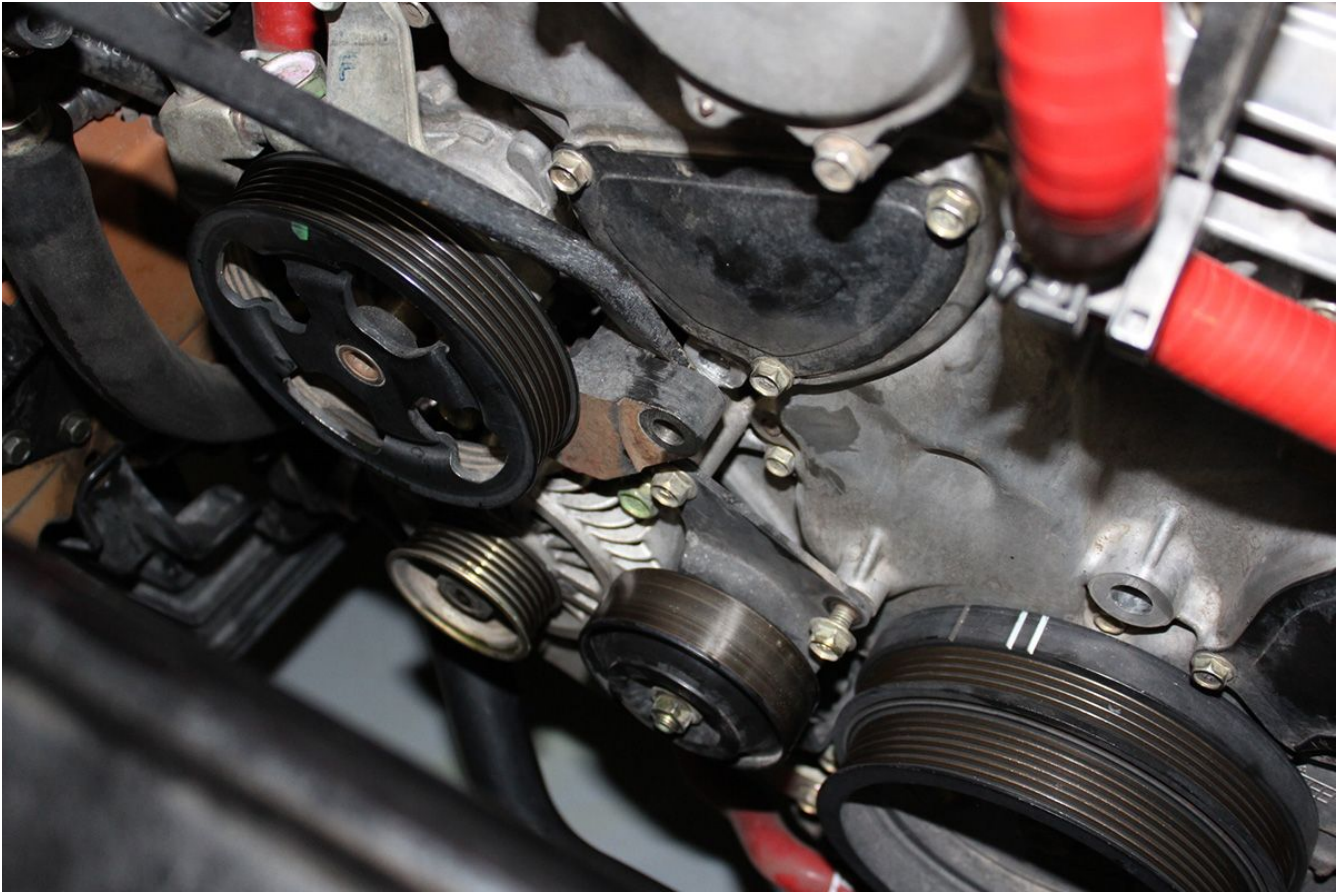

7. Then, slide the spacer in place. Again, it may help to use a tool to hold it in place while you get the bolt started.

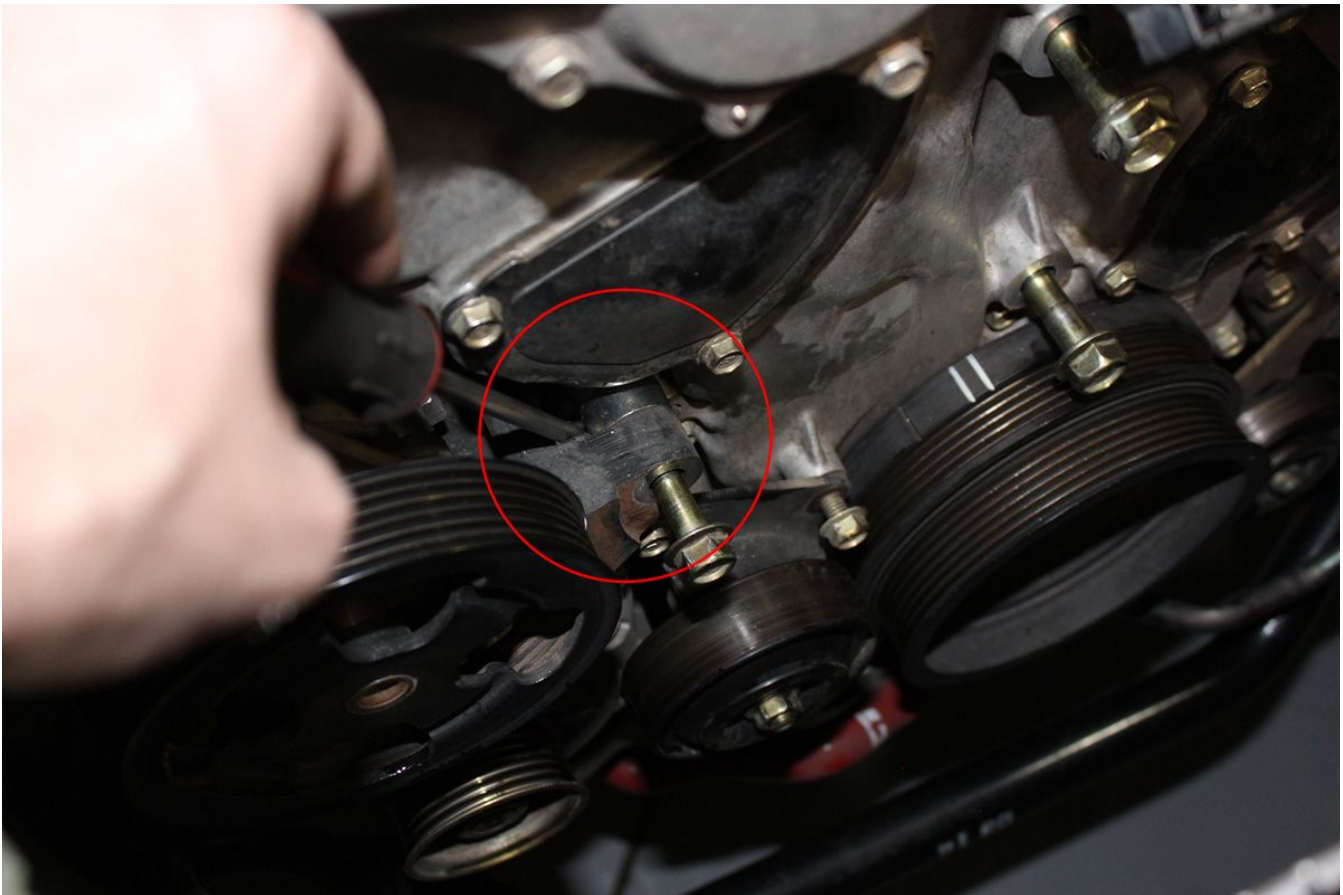

8. Almost there, go ahead and snug down that bolt.

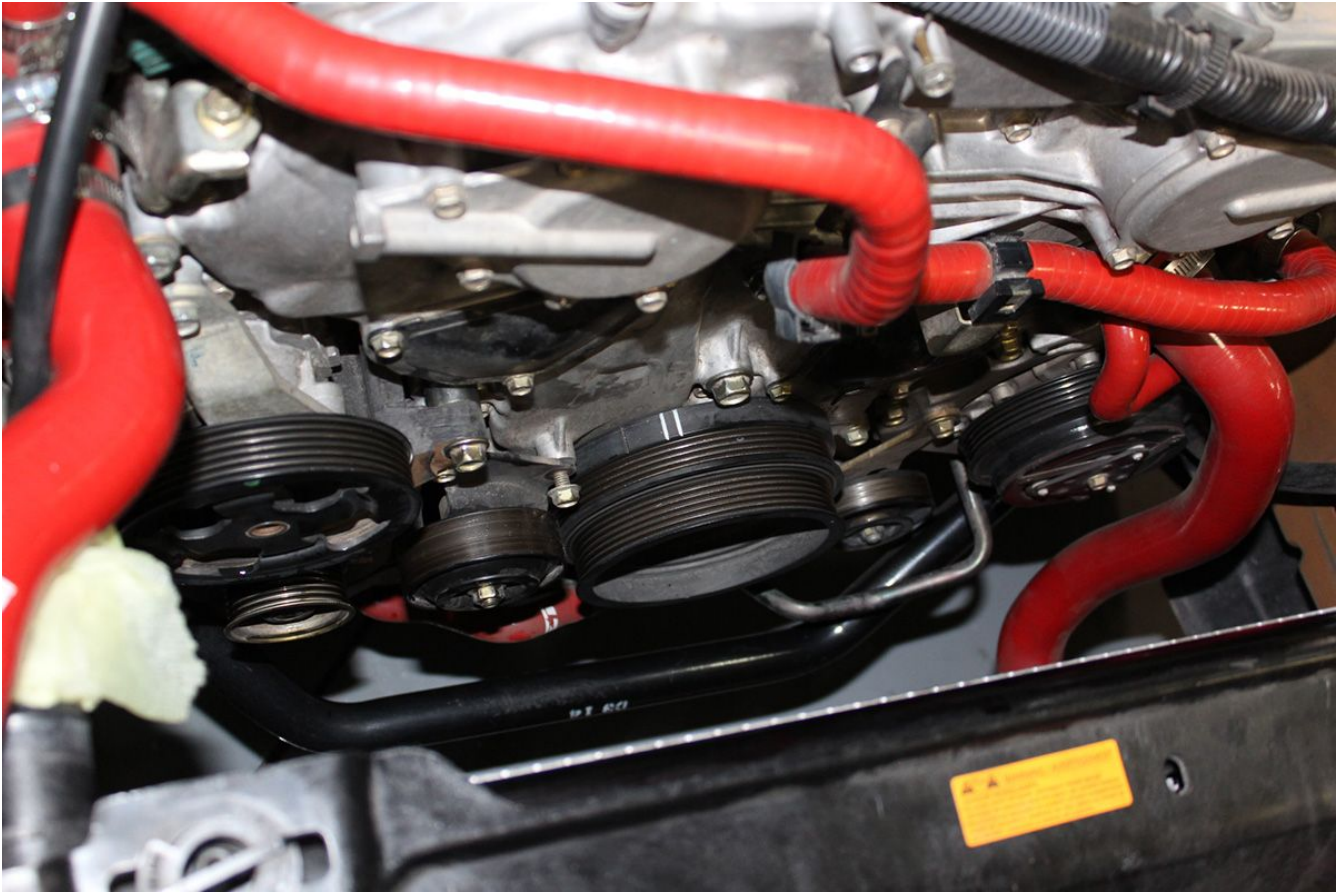

9. Install the new belt. Refer to this diagram if you need help with routing.

